

The PV Series of self-pressurising cryogenic vessels for liquid nitrogen are suitable for a host of applications within the industrial, medical, research and cryo-biological fields.

Each vessel has been designed to maintain pressure at a pre-set level using the integral pressure building circuit.

SPECIFICATION	PV 30	PV 60	PV 120	PV 160	PV 200	PV 240	PV 300	PV 400	PV 500	PV 1000	PV 2000
Product Code	9912-5030	9912-5060	9912-5120	9912-5160	9912-5200	9912-5240	9912-5300	9912-5400	9912-5500	9912-51000	9912-2000
Capacity (litres)	30	60	120	160	200	240	300	400	500	1000	2000
Diameter (mm)	410	461	538	640	640	691	691	768	998	1058	1310
Base (mm)	430	490	550	680	680	705	705	798	1040	1250	1400
Height (mm)*	955	1150	1416	1457	1591	1587	1972	1845	1547	2295	2810
Weight Empty (kg)	42	60	112	120	143	150	167	196	240	590	1050
Weight Full (kg)	66	102	187	249	304	344	409	519	644	1627	2585
Maximum Allowable Working Pressure (bar G)	4.0	4.0	4.0	4.0	4.0	4.0	4.0	4.0	4.0	4.0	4.5
Static Evaporation Rate (% per day)**	3.3	2.0	1.2	1.1	0.9	0.8	0.8	0.7	0.6	1.2	1.1

* Measured from floor to top of contents gauge

** Measured at atmospheric pressure

PV SERIES

The PV series are manufactured from stainless steel and can be operated in all environments with excellent evaporation rates. Each vessel is fitted with an electronic contents gauge for accurate measurement of liquid level.

All units up to the PV 500 are fitted with heavy duty castors, and tow bars fitted from the PV 120 to PV 400 (optional on the PV 120 and PV 160)

All the units have a safety relief valve, burst disc & a pressure gauge, plus all the units except from the PV 1000 & 2000 have a dual fill/decant valve.

Flexible Dispensing Hose 2m Product Code	3000-0241
Flexible Dispensing Hose with Handle 2m Product Code	3000-0240
Phase Separator Product Code	8000-3021

TPV SERIES

The TPV Series are designed to TPED, approved for transporting full on European roads



VALVES/PIPEWORK

PV 30 - PV 500

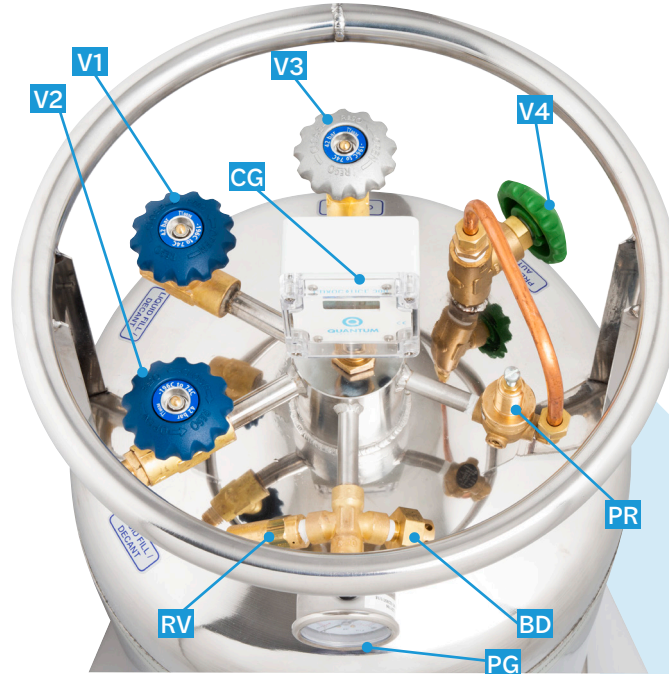
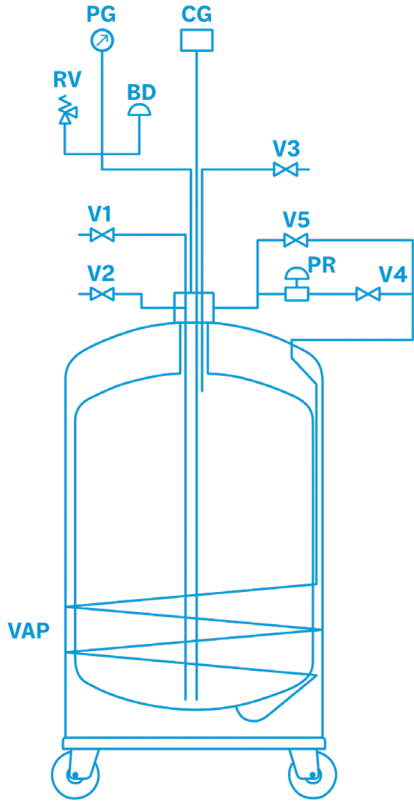

STANDARD ARRANGEMENT	
V1	Liquid fill/decant valve
V2	Liquid fill/decant valve
V3	Tri cock/gas vent/valve
V4	Auto pressure raising valve
V5	Manual pressure raising valve (optional)
PR	Pressure regulator
PG	Pressure gauge
RV	Relief valve
BD	Burst disc
CG	Contents gauge
VAP	Pressure build vaporiser

PV 1000 - PV 2000

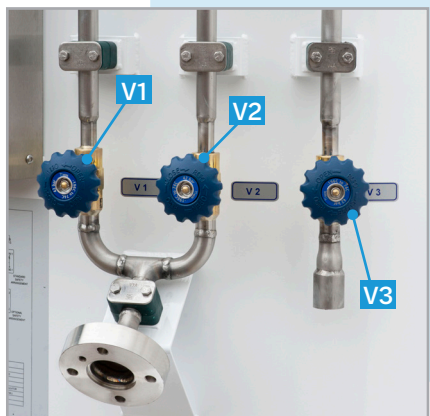
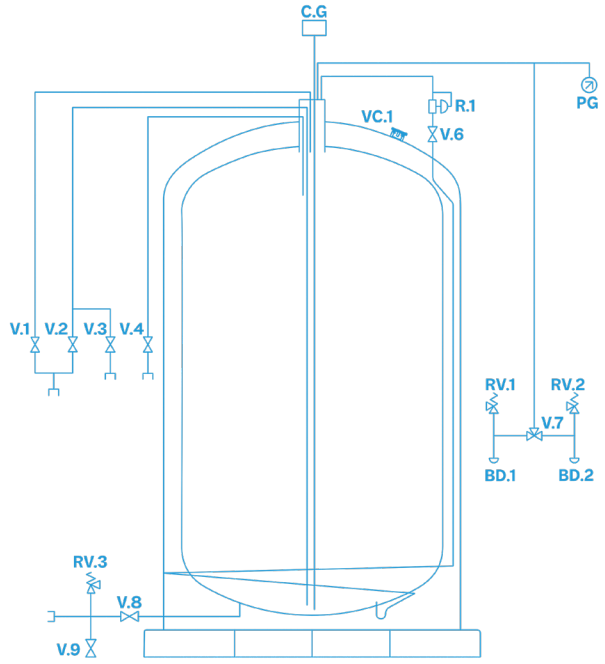

STANDARD ARRANGEMENT	
V1	Top fill valve
V2	Bottom fill valve
V3	Liquid decant valve
V4	Tri cock / vent valve
V6	Pressure build valve
V7	Change over valve
V8	Bottom decant valve
V9	Blown down valve
RV.1/2	Primary relief valve
RV.3	Line relief valve
BD.1/2	Burst disc
R.1	Pressure build regulator
C.G	Contents gauge
P.G	Pressure gauge
VC.1	Vacuum port

